





NFK 52 SOFT CLOSE SLIM LINE SLIDING SYSTEM FOR GLASS DOORS

NFK Glazing
& Industrial Supplies

www.nfk.com.au

 28 Devlan Street,
Mansfield, QLD 4122

 07 3343 3377

 sales@nfk.com.au

 42 Tacoma Circuit,
Canning Vale, WA 6155

 08 9455 3866

 wasales@nfk.com.au



NFK GLAZING & INDUSTRIAL SUPPLIES

MODERN SOFT CLOSE SLIM LINE SLIDING SYSTEM

- NFK Slim-line Sliding Door System is **aesthetic, sturdy** and **versatile** in both **construction and design**.
- The **sightline is only 51mm** comprising a single piece extruded aluminium track with a clip-on cover and end caps at both ends.
- **A smooth rolling motion** is provided by **three independent rollers** attached to the clamps.
- Rollers facilitate and prevent the clamp assembly from jumping off the track.
- The **hydraulic damper** within the track operates as a **soft closing mechanism**.
- NFK Slim-line Sliding Door System is **efficient and economical**. There is no need for any glass clamping notch preparation.

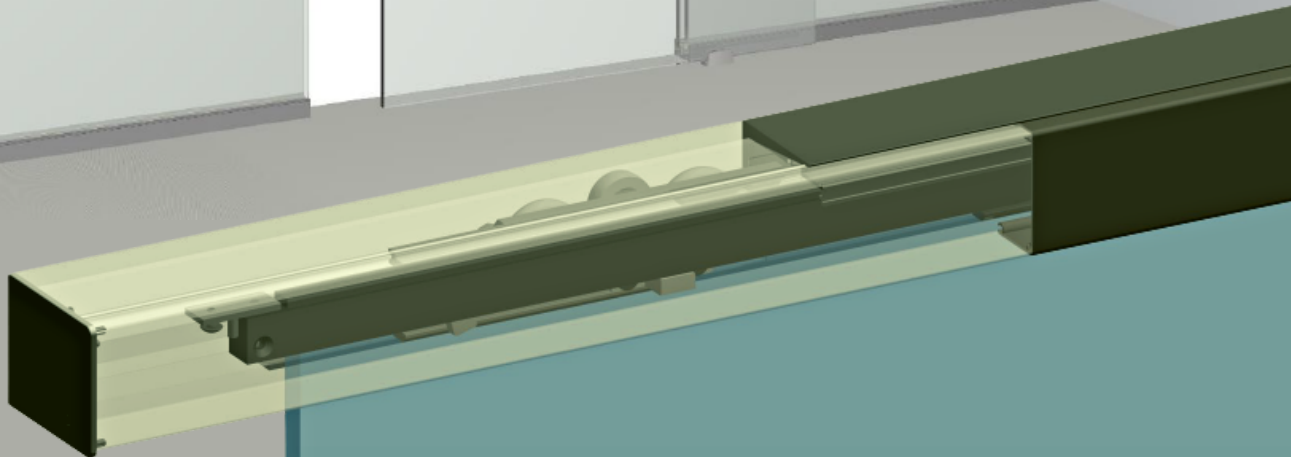

NFK Glazing & Industrial
Supplies

www.nfk.com.au

 28 Devlan Street,
Mansfield, QLD 4122
 07 3343 3377
 sales@nfk.com.au















 42 Tacoma Circuit,
Canning Vale, WA 6155
 08 9455 3866
 wasales@nfk.com.au



NFK GLAZING & INDUSTRIAL SUPPLIES

SLIM-LINE SLIDING DOOR SYSTEM KITS CODES

NFK SLIM-LINE SLIDING DOOR SYSTEM KITS

Length / Finish	brushed satin	natural anodised	matt black
2 m		19-108.2.1.11 	19-108.2.1.44 
3 m	19-108.3.1.77 	19-108.3.1.11 	19-108.3.1.44 
	19-108.3.1.77FP 		19-108.3.1.44FP 
4 m		19-108.4.1.11 	19-108.4.1.44 
			19-108.4.2.44 
5 m		19-108.5.1.11 	19-108.5.1.44 
		19-108.5.2.11 	19-108.5.2.44 
Accessories Kit		19-108AK	



Single door



Double door



Single door with sidelite





NFK GLAZING & INDUSTRIAL SUPPLIES

COMPONENTS OF THE SLIM LINE SLIDING SYSTEM

1

ALUMINIUM TOP TRACK

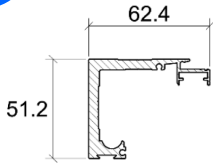

ck

2

ALUMINIUM CLIP-ON COVER

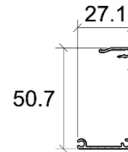

3

THREE WHEEL CARRIAGE



4

HYDRAULIC DAMPER



5

END CAP

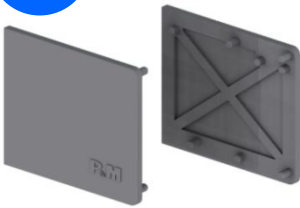

6

SINGLE-U STAINLESS STEEL FLOOR GUIDE

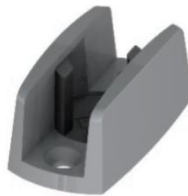

7

TRACK TO GLASS CONNECTOR



8

ALUMINIUM COVER PIECE

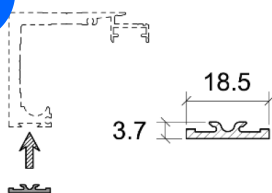

9

DOVETAILED U-CHANNEL

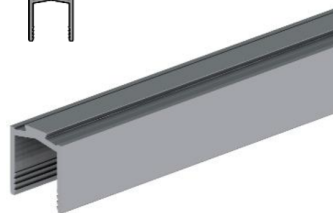
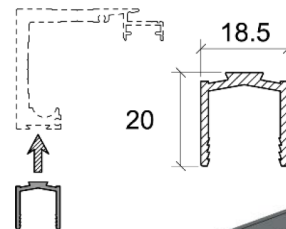

10

BOTTOM U-CHANNEL

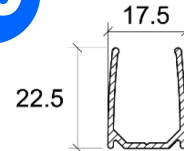



NFK GLAZING & INDUSTRIAL SUPPLIES

WALL MOUNTED SLIDING DOOR SYSTEM

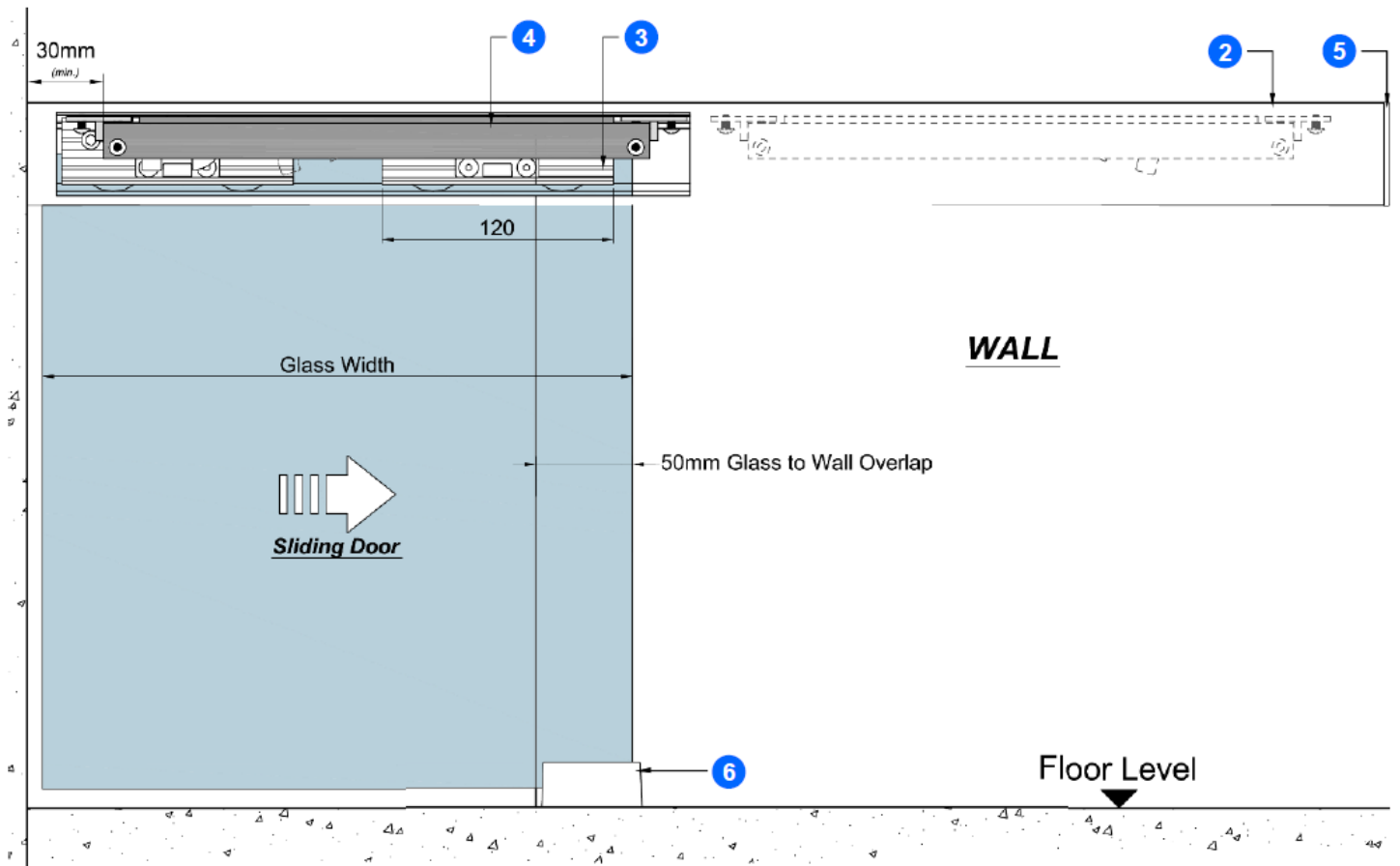

WALL MOUNTING SLIDING DOOR SYSTEM KIT COMPONENTS:

1 Aluminium top track	1
2 Clip-on aluminium cover	1
3 Three wheel carriage	2
4 Hydraulic damper	2
5 End cap	2
6 Single-U stainless steel floor guide	1
8 Aluminium cover piece	Extra

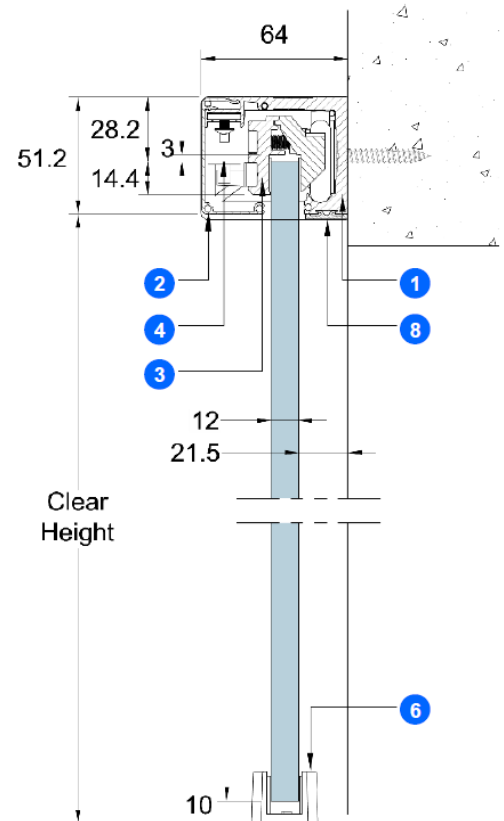



NFK GLAZING & INDUSTRIAL SUPPLIES

CEILING MOUNTED SLIDING DOOR SYSTEM

#	CEILING MOUNTED SLIDING DOOR SYSTEM COMPONENTS:	QTY
1	Aluminium top track	1
2	Clip-on aluminium cover	1
3	Three wheel carriage	2
4	Hydraulic damper	2
5	End cap	2
6	Single-U stainless steel floor guide	1

#	MOUNT WITH SIDELITE BELOW TRACK	QTY
9	Dovetailed U-channel	1
10	Bottom U-channel	1

#	MOUNT WITH SIDELITE BEHIND TRACK	QTY
7	Track to glass connector	1
8	Aluminium cover piece	1
10	Bottom U-channel	1

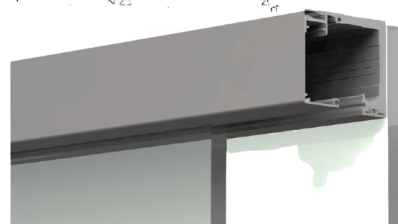
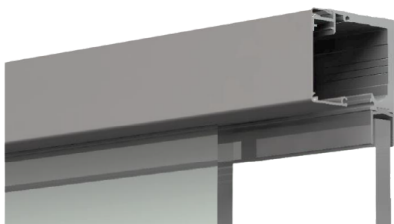
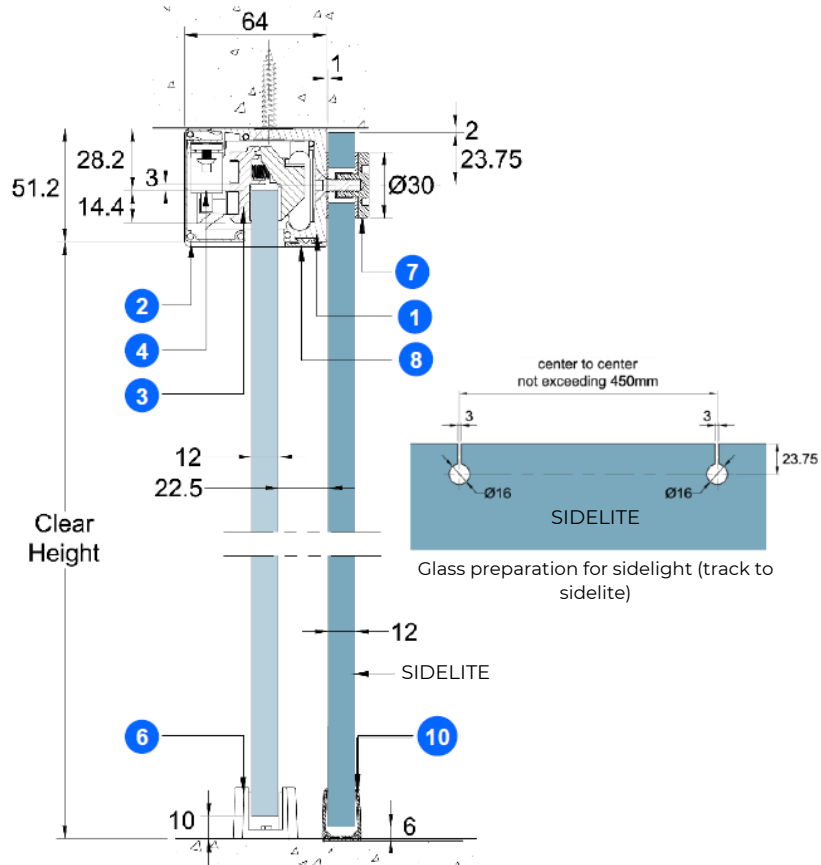
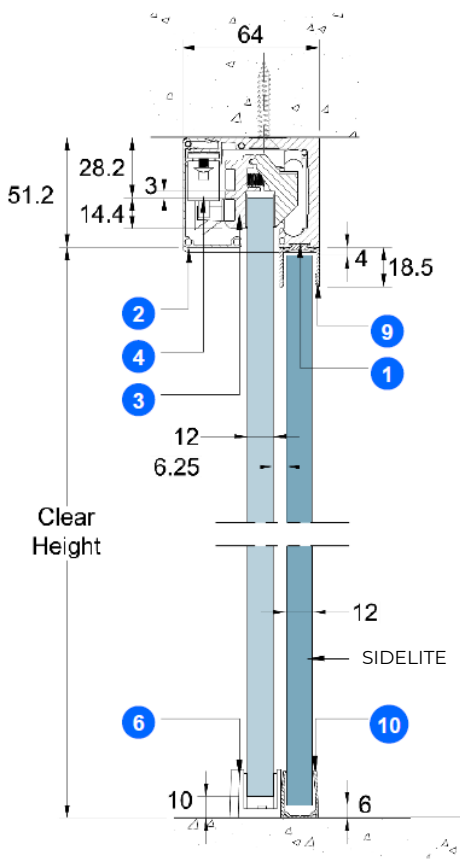



NFK GLAZING & INDUSTRIAL SUPPLIES

OVERPANEL AND SIDE PANEL MOUNTED SLIDING DOOR SYSTEM

HIGHLITE AND SIDELITE MOUNTED SLIDING DOOR SYSTEM COMPONENTS: QTY

1	Aluminium top track	1
2	Clip-on aluminium cover	1
3	Three wheel carriage	2
4	Hydraulic damper	2
6	Single-U stainless steel floor guide	1
7	Track to glass connector	1
8	Aluminium cover piece	1
10	Bottom U-channel	1

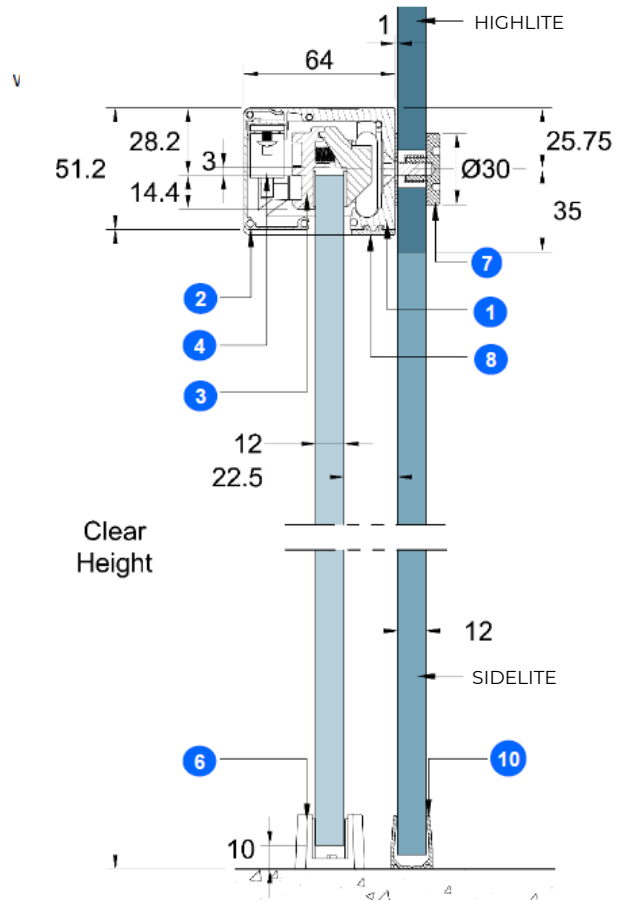

Front elevation drawing on the page 8





SINGLE LEAF DOOR MOUNTED TO HIGHLITE & SIDELITE

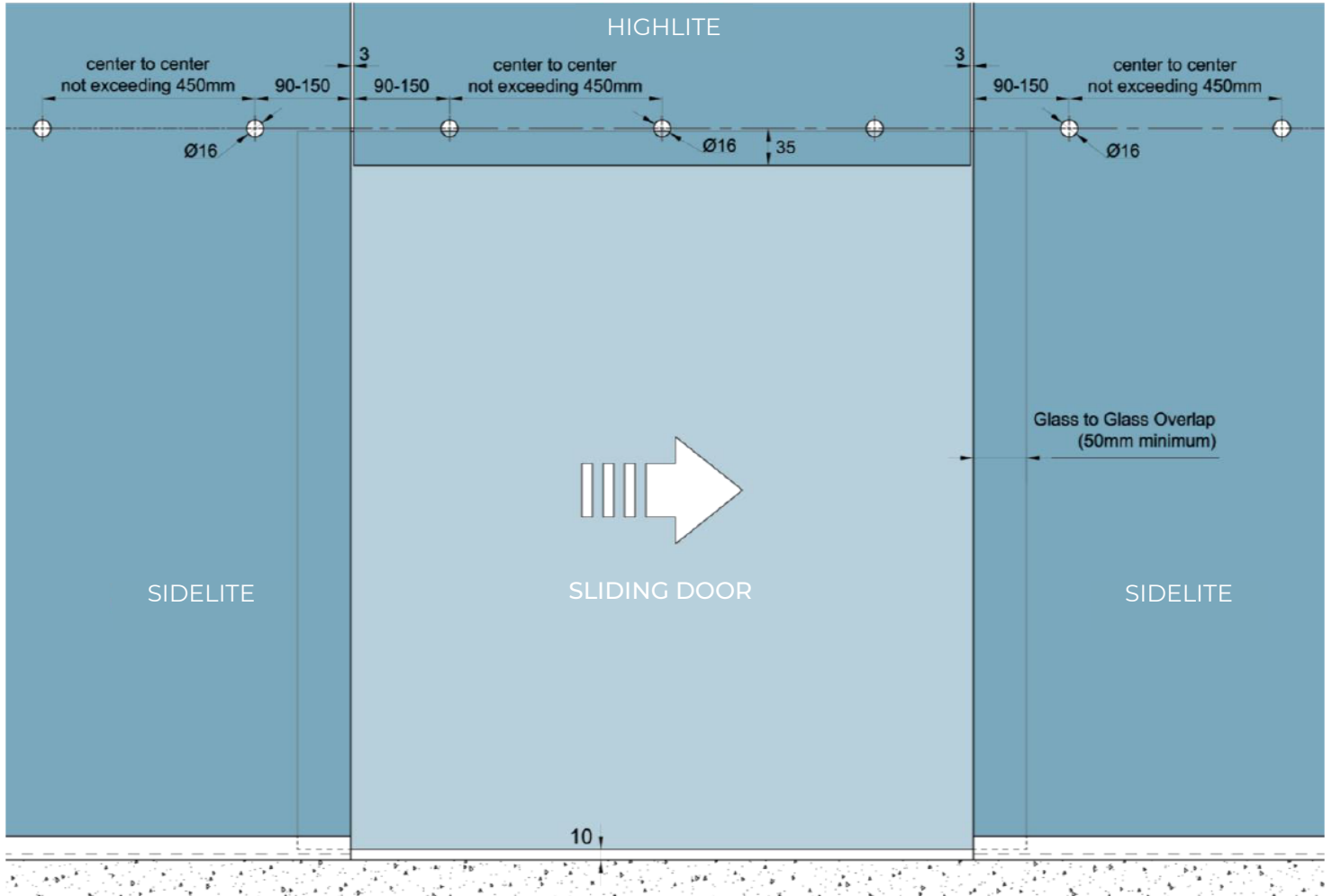

DOOR SPECIFICATION

Minimum Door Width:	600 mm
Maximum Door Width:	1000 mm
Maximum Door Height:	2700 mm
Maximum Door Weight:	80 kg
Glass Thickness:	8 -13.52 mm

If your glass panels exceed maximum door specifications it's a subject to technical consideration. Please discuss it with NFK staff.