



X1U SERIES

TRADE HINGES RANGE

- ✓ High-quality manufactured hinges with durable finish
- ✓ Suits U-shape cut-out
- ✓ Suitable for 10 mm glass thickness

Hinges Capacities

Number of hinges on one door	Max. weight	Max. width
2	35kg	710mm
3	54kg	810mm

NFK Glazing
& Industrial Supplies

www.nfk.com.au

📍 28 Devlan Street,
Mansfield, QLD 4122

☎ 07 3343 3377

✉ sales@nfk.com.au

📍 42 Tacoma Circuit,
Canning Vale, WA 6155

☎ 08 9455 3866

✉ wasales@nfk.com.au

X1U Glass to Glass 90°

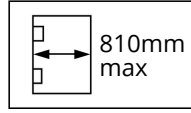
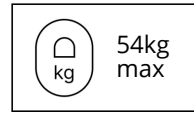
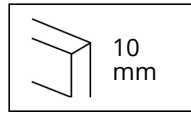

High-quality square glass-to-glass hinge 90°

FINISH	CODE
Chrome	19-SH/028C
Matt Black	19-SH/028MB
Brushed Nickel	Contact NFK
Gold	Contact NFK
Other finishes	Contact NFK

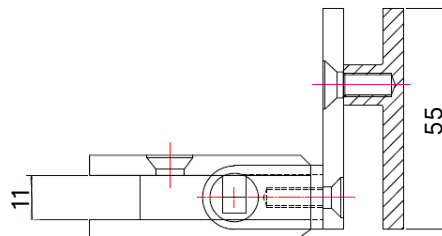
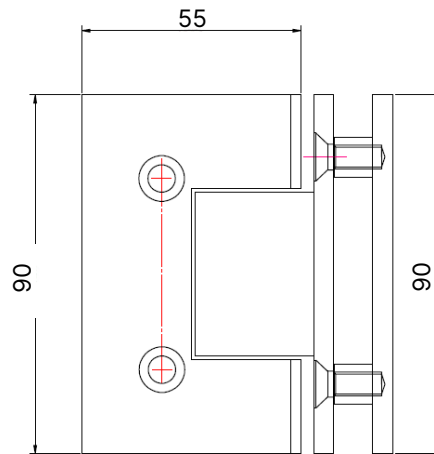
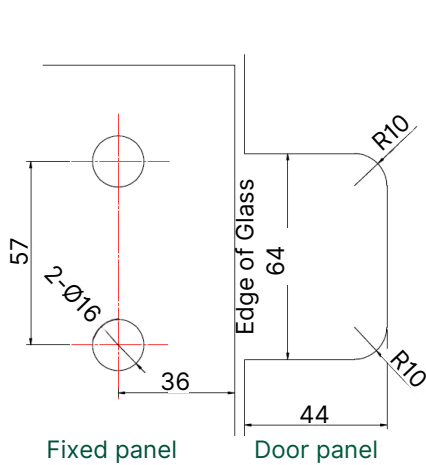

NFK Glazing
& Industrial Supplies

www.nfk.com.au

28 Devlan Street,
Mansfield, QLD 4122

07 3343 3377

sales@nfk.com.au

42 Tacoma Circuit,
Canning Vale, WA 6155

08 9455 3866

wasaless@nfk.com.au