



KAPPEL VACUUM LIFTER DSKE2 - 12V

KAPPEL Vacuum Lifter DSKE2-12V (Vac Rig 450kg InLine) is a German-engineered glass vacuum lifter designed for safely handling long, narrow glass panels such as fins. Featuring a 6-cup in-line configuration with dual independent vacuum circuits for maximum safety, it can be expanded with load-bearing extensions to increase glass length and capacity. Supplied on a lightweight trolley.



Onboard control
Also available for hire

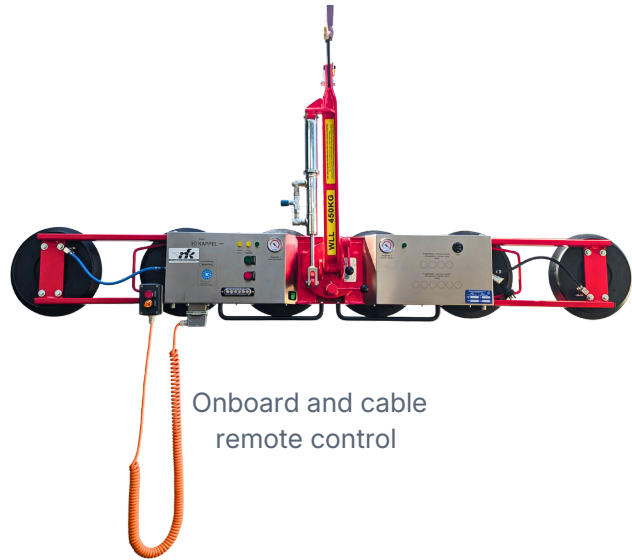

Onboard and cable remote control

Vacuum Lifter Options	Code
Onboard control	35-VDSKE212V-450
Onboard and cable remote control for suction, release with quick release function	35-VDSKE212VSRR-450

KAPPEL VACUUM LIFTER DSKE2 - 12V

Onboard and cable remote control



Supplied standard with an onboard control panel and cable remote control. A radio remote control is also available as an optional extra.

Technical characteristics

Rated Lift Capacity: 450 kg (6 cups) * / 300 kg (with 4-cup setup)

Rotation: 360° manual, lockable every 45°

Power supply: 12 V battery mains-independent with integrated charger

Tilt: 90° manual, stepless, with lowering cylinder

Power Supply: 12V battery with integrated 240V charger

Accessories (Standard Set): Lightweight trolley, two extension arms, individual fabric covers for suction cups

Safety & Monitoring: Dual vacuum circuits (independent), dual vacuum gauges, optical & audible alarms, visible voltmeter

Optional Extras: Radio remote control for suction/release with quick-release function

NFK Glazing
& Industrial Supplies

www.nfk.com.au

28 Devlan Street,
Mansfield, QLD 4122

07 3343 3377

sales@nfk.com.au

42 Tacoma Circuit,
Canning Vale, WA 6155

08 9455 3866

wasaless@nfk.com.au

DRAWINGS

WLL-450kg

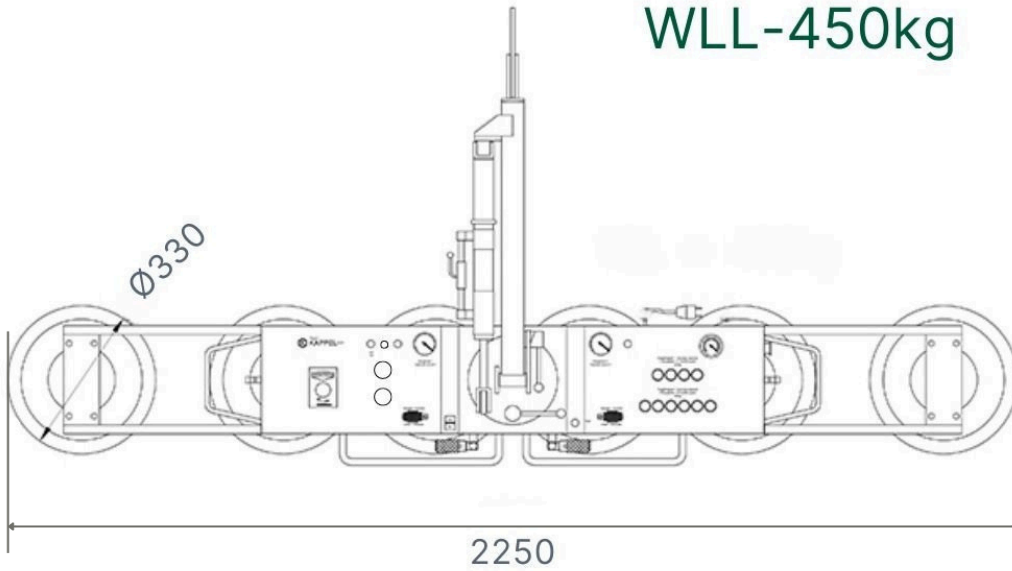

WLL-300kg

