

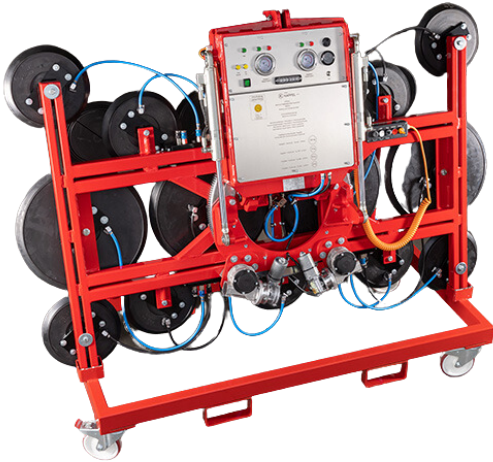

Glass Lifting & Handling Equipment | DSMH2/12V

KAPPEL VACUUM LIFTER DSMH2/12V



- Designed, engineered and manufactured in Germany in 2022
- Hydraulic tilting
- Dual vacuum system: 2 vacuum circuits, independent of each other
- An adjustable lifting eye allows the glass to hang as vertically as possible
- The narrow 320mm deep frame is ideal for working between structure and scaffold
- A flexible design allows all pads to be removed and reconfigured as required for odd-shaped/narrow glass, attaching unique lifting frames etc.
- The dual vacuum gauges display the current vacuum pressure for both circuits
- Optical and audible warning signals are standard, as is a visible volt meter
- Supplied on a lightweight trolley

Technical characteristics

Suction pad/cups: 4 pieces, type 400K and 16 pieces, type 150K

Extensions: 4 piece

Lift Capacity: 1550 kg with 14 suction cups, without extensions
2000 kg with 20 suction cups, with 4 extensions

Total Rig Weight: approx. 420 kg

Options: Radio remote control

Tilt: 90° hydraulic

Rotate: 360° electric

Two vacuum plumps: 12V, DC, nominal current approx. 4A/pump

Power supply: Two batteries: nominal voltage - 12V, DC, nominal capacity - 26Ah
main voltage - 230V, AC; 50Hz

- Features:**
- The voltage indicator shows the battery charge level
 - The vacuum display shows the current vacuum level
 - Acoustic warning signal when the vacuum is undershot

NFK Glazing
& Industrial Supplies

www.nfk.com.au

 28 Devlan Street,
Mansfield, QLD 4122

 07 3343 3377

 sales@nfk.com.au

 42 Tacoma Circuit,
Canning Vale, WA 6155

 08 9455 3866

 wasales@nfk.com.au

DRAWINGS

WLL-1550kg

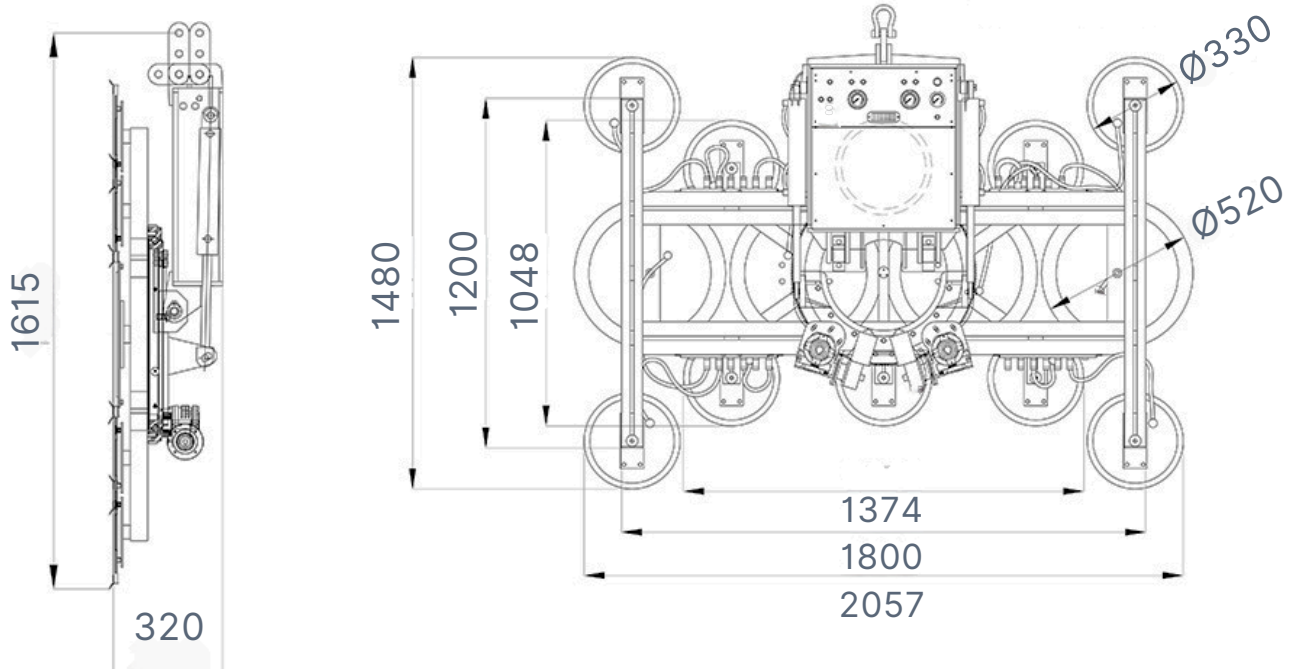

WLL-2000kg

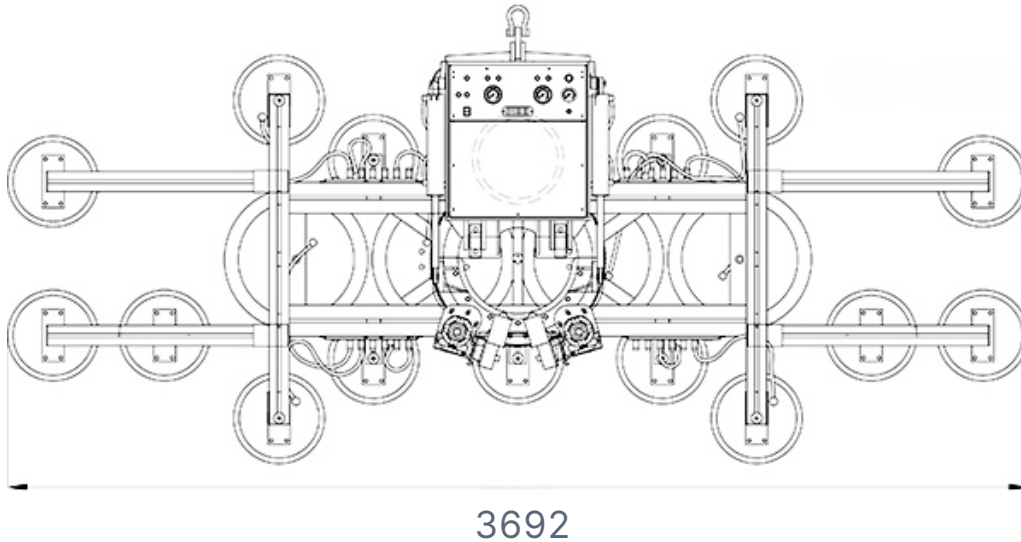

NFK Glazing
& Industrial Supplies

www.nfk.com.au

28 Devlan Street,
Mansfield, QLD 4122

07 3343 3377

sales@nfk.com.au

42 Tacoma Circuit,
Canning Vale, WA 6155

08 9455 3866

wasales@nfk.com.au